

Neptune

**A few words from our customers...
...and about our customers.**

We'd like to thank all of our customers for their support in making the Neptune Series a success and welcoming us into each of your marinas. As you read about each of our customers and their marinas, you will see how each location has charm to it. Whether it be a little or a lot, each marina gives something unique to its customers. Some of the locations have a storied history behind them, while others are currently in development waiting to be the next modern-day marina.

What all the marinas and the people that run them have in common is their dedication to their customers. From retrieving and prepping a customer's boat for a day on the water to a clubhouse where customers can sit back and relax, these marinas strive to give their customers the ultimate boating experience.

We're honored to be part of that experience.



Gasparilla Marina

Placida, Florida

M220 Neptune Series
First Neptune manufactured

Marina overview

Located in Placida, Florida, Gasparilla Marina is the area's largest deepwater marina offering direct, uninterrupted access to the Gulf of Mexico and Charlotte Harbor, making it the perfect layover and homeport for larger yachts.

Gasparilla is home to the largest dry storage facility in the area with more than 500 dry slips, which includes a new dry storage facility. The new enclosed dry storage facility is a state-of-the-art facility with a 300-boat capacity, accommodating boats between 23 and 45 feet.

Wet slips can accommodate boats from 20 feet up to 65 feet with numerous T-Heads available for larger vessels up to 100 feet in length. Covered slips can accommodate boats up to 60 feet and offer boaters a little extra protection from the elements. All 30-foot and larger slips offer 30- and 50-amp electric service, as well water hook-ups. Gasparilla also offers a Boat Lift Program where boaters may have a boatlift installed in their slip.

Gasparilla also offers fishing charters, boat rentals and Bait & Tackle Shop. At the shop, guests can purchase a variety of items such as live and frozen bait, terminal tackle, lures, jigs, rod/reel combos, sportfishing t-shirts, hats, sunglasses, ladies and kids clothing, as well as ice, beer, soda and snacks.

John Chaplin, assistant general manager, and his Neptune M220.

Thoughts on the Neptune Series

Mike Wisatsky, owner; John Chaplin, assistant general manager; and Gasparilla forklift operators

"Marty [Flaska] and Hoist have gone above and beyond with their service. They understand that the name of the game is rack 'em and stack 'em, and downtime is a killer for a marina. They are right on the spot, shipping parts and keeping the truck running, no questions asked and dealing with the details later. I've dealt with [a competitor] who needed to know every little detail before any action was taken, if at all, and we can't have that. We've had the [Neptune] for about a year and I compare it to a Ferrari. It is better than anything on the market and time will tell if it continues to be the best, but I'm very confident that it will." - Mike

"We'll run over 100 boats in and out of the water and racks in a single day and the Neptune meets the demand we require from it. It's a workhorse and our main forklift in operation." - John

"The visibility is fantastic, especially out the rear. It's a very comfortable and smooth ride, which is great for us since we move so many boats everyday. The quickness of the hydraulics is nice and the tall overhead guard let's us stand up and look down when we're lowering boats into the water." - forklift operators

Grove Key Marina

Miami, Florida

**M250 Neptune Series
Delivered June 2006**

Marina overview

Grove Key Marina is a full-service marina, which includes interior and exterior storage, fuel (gas and diesel), boat haul-out and service/maintenance. Boats can be stored on cradles inside one of the marina's two hangars or outside on any of its 320 hi and dry rack spaces. Grove Key Marina is one of the busiest marinas in the Miami area with a distinguished list of cliental and a one-and-a-half-year waiting list.

Aviation history and a Silent winch

Though Grove Key Marina took delivery of a Neptune Series marina forklift from Hoist Liftruck in June 2006, the history of the property the marina sits on and Hoist Liftruck go back more than 75 years.

Dinner Key, on Biscayne Bay in Coconut Grove, Florida, served as a U.S. navel air base until the end of World War I. Non-scheduled, commercial airplanes used the facility until it was destroyed by the 1926 Miami Hurricane.

In 1930, Pan American Airways (Pan Am) selected the former navel air base for its inter-American flights after acquiring New York-Rio-Buenos Aires Airline, which flew flying boats between Miami and Buenos Aires. Between 1931 and 1938, four hangars were constructed to house and service Pan Am's fleet of Clipper seaplanes, as well as its new terminal building.



Dinner Key area during WWII and present day.

Above photo courtesy of National Archives.



The terminal building was more than a place for departing and arriving travelers, providing an international postal office, public health services, customs, and immigration and ticket counters. The building also attracted thousands of visitors with its three-and-a-half-ton revolving globe that was located in the lobby, as well as its prominent second floor amenities.

"Travelers and guests could view takeoffs and landings from the terminal building's second floor restaurant and cocktail lounge," explains Paul Turcotte, general manager of Grove Key Marina. "Many of the world's wealthiest people and famous stars sat in that lounge and restaurant."

During World War II, Dinner Key again served as a base for the U.S Navy, but still continued to serve its international passengers. As some time passed and airfields started to appear in Latin America, the need for seaplanes decreased. Pan Am's final flight to Dinner Key was on August 9, 1945.



Today, the former terminal building is now Miami City Hall, which was converted in 1954. Grove Key Marina sits on a significant portion of the property and it continues to use two of the original four Pan Am hangars as boat storage and service area. The basin where tracks used to tow the Clipper seaplanes in and out of the water is now used by Grove Key Marina to launch and retrieve boats with its marina forklifts.

"The tracks are still visible in the water and show no signs of rust after all these years," states Turcotte. "In fact, the original winch system that operated the tracks and the shed that housed it is still here as well."

The winch used back in the 1920s was manufactured by Brooklyn, New York-based Silent Hoist & Crane, the historic company that is now Hoist Liftruck.



Manufactured by Silent Hoist & Crane, the original winch used more than 75 years ago is still intact at Grove Key Marina.

Thoughts on the Neptune Series

Paul Turcotte, general manager

"I really like the corrosion protection on the truck, especially the galvanizing and three-step paint process. Quality standard components, like the Cummins engine, were key selling points."

"Hoist has been great at rectifying any issues on the truck, assessing our needs and making necessary corrections and repairs. I've seen the frequent breakdowns and poor service support on other trucks, which helped us narrow our options and eventually led to the Neptune."



Staff at Grove Key Marina.

Nautico Boat Club

St. Petersburg, Florida

M520 Neptune Series

Scheduled for delivery Summer 2007

Marina overview

Scheduled to be completed this summer, Nautico Boat Club plans to offer its clients first-class service and facilities. Nautico will offer concierge services; high-speed gas and diesel pumps; members-only wholesale fuel pricing; clubhouse facility; lounge area with banquet and bar facilities; stainless fish cleaning station with poly-cutting boards and chum grinder; 24/7 electronic security; lightning/storm warning system; and boat broker/dealer/resale/leasing services.

The high & dry boathouse will store up to 327 boats and is structurally engineered with reinforced steel frame construction to withstand winds up to 140 mph. The dry slips will accommodate boats from 30- to 45-feet long, up to 15-feet wide and up to 20-feet tall. The boathouse will also feature fire suppression system with 24/7 monitoring; after-hours key-drop and next-day storage; unlimited splash service during operating hours; special poly extruded, non-marking bunk covers; articulated boom lift for access and maintenance; floating concrete staging docks; outdoor wash and staging racks; and low-dust environment.

Nautico's 143 wet slips will accommodate boats up to 55-feet long. Features of the wet slips include Storm-Protected™, fixed-floating concrete dock system with tidal-adjusted cleating; surge-protected docks surfaced with cool brushed concrete and new concrete-capped PVC seawall. Each wet slip will also have marina power and light, night-lighted power pedestals with water, optional telephone and cable television service available. Each pedestal will also have 20- to 30-amp, 110- to 120-volt and 50-amp, 220-volt service.



(above) Nick Shaffer, marina manager. (left) Rendering of completed project.

Thoughts on the Neptune Series

Nick Shaffer, marina manager

"The Neptune had the latest technology and modern appearance we were looking for. The RemoteTech system will be a great feature for us, monitoring the functions of the truck."

"The ergonomics of the truck are great. The air-ride seat, electronic joystick controls and visibility are key for our operators."



Joe and Lucy Ambrose, owners, on their Neptune Series M250.

Snapper Marina

Hernando Beach, Florida

M250 Neptune Series

Delivered September 2006

Marina overview

Purchased by Joe and Lucy Ambrose in March 2002, Snapper Marina features high and dry storage, wet slips and yard storage. Customer service is key at Snapper Marina, offering its clients with boat fuel-up, boat wash, engine flush, and fresh water on board their boats. The staff at Snapper Marina is currently renovating and expanding their facility. The current dry storage facility is being reskinned and additional racks are being constructed, as well as new concrete surfaces. Scheduled to be completed this fall, Snapper Marina will have more than 300 dry slips and approximately 20 wet slips.

As the Hernando Beach area continues to grow, the Ambroses are preparing to accommodate the influx of new residents including a baseball player from the Houston Astros who will store his major league boat at Snapper Marina.

Thoughts on the Neptune Series

Joe Ambrose, owner

"I really like the visibility through the mast and out the back. The truck drives and shifts smoothly. The electronic joystick controls are easy to operate, as well as the emergency brakes. I also like the sleek appearance and the standard Cummins engine. The service that Hoist has provided has been outstanding."

Tierra Verde Resort/Marina

Tierra Verde, Florida

**M250 Neptune Series
Delivered August 2006**

Marina overview

Located on an Tierra Verde, an island on the southern tip of Pinellas County, Tierra Verde Resort/Marina is near the Gulf of Mexico, Intercoastal Waterway and Tampa Bay.

Tierra Verde R/M has 151-capacity high and dry storage facility, 21 outside storage spaces and 98 wet slips. The high and dry facility can accommodate boats up to 42 feet and features a fire protection system that can pump 25,000 gallons of water per minute in case of an emergency. Boats will be retrieved from the water, engine flushed and boat rinsed as a service to its customers. The marina's wet slips can accommodate boats up to 130 feet and has a channel depth of 12 feet.

Customers can also purchase ice, snacks, drinks and other items at the on-site convenience store. Gas and diesel are also available with tenants receiving a 10-cent/gallon discount.

The island of big stars

Canadian-born musician Guy Lombardo, with a taste for the extravagant, opened his Port O'Call Resort at Tierra Verde in January 1963, a year after the completion of the bridge and road that finally connected the island to the mainland.

Lombardo, who frequented the Las Vegas scene, wanted to open up a similar high-profile venue in Tierra Verde, a favorite vacation spot.

"Lombardo wanted the biggest and best, just like Vegas," says Bernie Hefner, Tierra Verde R/M's marina manager. "He really lobbied for a gambling permit, but was never granted one. He did accomplish building a lavish resort with the largest swimming pool in Florida at the time."

The Port O'Call Resort attracted thousands of visitors, including a few famous ones. Stars such as Frank Sinatra, Liberace, Marlene Dietrich and Mel Torme performed there and some joined Lombardo on a 10-week national tour to more than 20 cities. Lombardo heavily promoted his resort and Tierra Verde



Bernie Hefner, marina manager of Tierra Verde Resort/Marina.

during the shows, as well as on their tour bus that donned a Tierra Verde banner.

Lombardo and his band of stars returned only for one more season following the death of the island's developers, Louis and Fred Berlanti, in August 1963.

Louis and his son Fred arrived from New York in 1961 after various partners and corporations sold them the islands and project

permits for the road and bridge construction. Louis was appointed to president of the Tierra Verde Community Association later that year. Speculation as to whose money Louis was representing pointed to Texas oil tycoon, Clint Murchinson.



When the bodies of the Berlantis were found in Lake Okeechobee after their airplane exploded, questions of the accident swirled around the area including possible under-the-table activities. Tierra Verde was handed over to Murchinson, who owned the island for 14 years when a new venture called Tierra Verde Company took over in 1977, the same year Lombardo passed away.



This mural detailing Tierra Verde's history is located at Tierra Verde Resort/Marina.

Thoughts on the Neptune Series

Bernie Hefner, marina manager

"Though we had some bugs to work through in the beginning, Hoist has stepped up to the plate and has provided excellent service. Al [Paradela] and the rest of the Hoist staff have given me a level of comfort that has myself and my staff very pleased."

"The Neptune is extremely comfortable to ride and easy to operate. The joystick controls cut down on the fatigue tremendously versus conventional hydraulic controls. The all-around visibility is excellent, especially through the mast."

Phillippi Harbor Club

Sarasota, Florida

**M250 Neptune Series
Delivered January 2007**

Marina overview

Phillippi Harbor Club is a modern rackominium marina club community located along Phillippi Creek. Opening in February 2007, Phillippi Harbor has 309-capacity dry storage facility built to strict fire and hurricane codes, withstanding winds up to 150 mph. Owners who purchase space at Phillipp Harbor receive first-class service and privileges.

"Our concierge service is what makes us stand out," states Ted "Dockboy" Stauffer, marina manager at Phillippi Harbor. "Call us ahead of time and we'll put your boat in the water, fuel up your boat, and stock your cooler with ice, drinks and snacks. When you come back, we'll retrieve your boat, rinse the boat with fresh water, flush your engine and store it back in your space."

In addition to these services, Phillippi Harbor offers on-site repair and maintenance services and private storage lockers for each unit.

"We're in a prime area of Sarasota and it's a boater's paradise," explains Stauffer. "We're close to all the beaches and islands, and only a few minutes from the Intercoastal and 15 minutes to the Gulf."

Ted "Dockboy" Stauffer, marina manager, stands with his Neptune Series M250 and operator, Alex Ortega.



Thoughts on the Neptune Series

Ted Stauffer, marina manager

"Our owner, Len [Nadolski], did the research and comparison on all the different marina trucks out there. He came to the decision to go with the Neptune in less than two hours. He knew exactly what he was looking for."

"We love the Neptune and how smooth and comfortable it rides. It handles big boats easily, which gives us a very secure level of comfort, as well as our customers. The ergonomics and controls are outstanding."

"The hydraulic gauge is a wonderful feature. Getting pressure readings are extremely easy. Also, the new rubber fork pads are great. The grips are solid and stick like glue."

Open Bay Marina

Merrick, New York

**M200s Neptune Series
Delivered August 2006**

Marina overview

Open Bay Marina was developed from a dilapidated piece of property. The full-service marina now consists of a new yard, gates, high and dry racks, docks and office.



Thoughts on the Neptune Series

Chris Badenhop, owner

"The short wheelbase on this Neptune is perfect for my marina. It's extremely maneuverable and handles all my boats with no problem. It's a smooth ride and the standard features are outstanding."

BoatClubsAmerica

Ft. Myers, Florida

**M440 & M250 Neptune Series
Scheduled for delivery in 2007**

Marina overview

Ft. Myers BoatClub will span 26 acres of land and water in a prime location on the Caloosahatchee River and will soon be the largest marina in Ft. Myers with nearly one mile of seawall and floating docks. Formerly Deep Lagoon Marina, Ft Myers BoatClub will have 90 BoatWetSlips accommodating boats between 40 and 85 feet in length and 354 BoatHouseSlips accommodating boats up to 42 feet, both options available for purchase. The North BoatHouse and South BoatHouse are engineered to meet current wind load criteria of 140 mph.

Ft Myers BoatClub will be a full-service marina with boats available seven days a week with hours of operation from dusk to dawn. Slip owners have unlimited haul and launch privileges. Staff members will help load up and cast off for the day, with golf cart service from parking to the launch areas. Upon return, staff members will flush the engine, rinse off the salt water and dry the boat before returning it to the BoatHouse.

The Clubhouse offers amenities such as two heated pools, billiard room, bar and fireplace, and conference room and business center. Ft Myers BoatClub will also offer locker room facilities complete with rest-rooms, private showers and vanities, private dressing areas and laundry room facilities. An 8,500-square-foot restaurant with outdoor seating will be available to marina guests and general public.



The state-of-the-art BoatServiceCenter will have six clean-space, enclosed work bays accommodating boats up to 70 feet. Ft Myers BoatClub can work with a boat owner's independent contractor or introduce owners to service providers that they have discovered. A 21,500-square-foot MarineMax Sales and Service Center will also be onsite.

Surrounding Ft Myers BoatClub is extensive landscaping and lighting features with brick-paver walkways and floating docks. There are natural preserve areas with boardwalks and an Osprey nest, as well as natural water features and constructed waterfalls, electronic sprinkler system with mosquito repellent and full-time staff members dedicated to environmental education and compliance.

The Developer

The BoatClubs concept came to life with the developer of Barefoot BoatClub in 1997 by Edward J. Ruff Development, Inc. Its success spurred a brand new parent company called BoatClubsAmerica. The core mission of BoatClubsAmerica is to develop new marinas and redevelop old marinas. To date, BoatClubsAmerica has done both.

After successfully completing Naples BoatClub and Barefoot BoatClub, BoatClubsAmerica is developing Ft Myers BoatClub and has



Ft Myers BoatClub will join Barefoot BoatClub in Naples, Naples BoatClub and Ft Lauderdale BoatClub

purchased a marina on the New River in Ft. Lauderdale -- Ft Lauderdale BoatClub.

Building on its success in the development of innovative marina properties, BoatClubsAmerica is now positioned with a history of commitment and experience to move forward on new marina acquisitions. Its continued mission is to duplicate BoatClubs throughout the most notable waterfront communities in Florida and throughout America. There are 10,000 marinas in America and 2,000 in Florida, and a great many are strong candidates for our redevelopment formula.

Many of the existing marina properties have been converted to residential developments -- because it's simpler. The permitting of marina facilities is complex due to environmental issues. The process of redeveloping a marina property requires a new methodology, a new concept, and the kind of in-depth experience BoatClubsAmerica bring to the project.

Strict environmental regulation has prevented the development of new marinas. Yet the demand is still growing for boat storage on rivers, inland waterways and bays throughout Southwest Florida and the United States. Existing marinas are old and in need of extensive repair. New building requirements and codes are far more stringent and costly to meet. Many long-time marina owners choose minor annual renovations over the high costs of complete redevelopment.

The land is the valuable component in the old marinas, and in effect they are "tear-downs." Selling wet slips, dry storage, and commercial space as condominium real estate properties provides the much needed capital to finance a redevelopment of these obsolete facilities. The end product is a beautiful and environmentally sound, state-of-the-art facility and BoatClub for boaters and the marine industry. The completed BoatClub properties must be low-maintenance, highly functional and aesthetically pleasing. Existing marinas are unable to simply renovate their older buildings and expect them to sell at a premium.

Thoughts on the Neptune Series

Pat Ruff, vice president

"We liked the history and structure of Hoist, which is similar to ours. Both companies try a meaningful approach to business and relationships."

"The visibility is excellent as well as the design with the low center of gravity. The RemoteTech system is a great concept, adding to the other modern features of the Neptune."

"Having a solid dealer network was critical for local support and Hoist showed aggressive delivery times."

Calusa Island Yacht Club & Marina Resort

Goodland, Florida

**M250 Neptune Series
Delivered June 2006**

Marina overview

Known as Southwest Florida's Gateway to the Ten Thousand Islands and Florida Keys, Calusa Island Yacht Club & Marina Resort offers boaters the ultimate vacationing experience. According to Kris Dane, the resort's managing director, Calusa is a destination for families and avid boaters who are looking for excellent fishing and beautiful sites.

Calusa's full-service marina offers covered rack storage for boats up to 40 feet and open-yard storage for boats up to 50 tons. The high and dry storage has a capacity of more than 250 boats, with more facilities currently being built that will more than double that capacity. Currently, there are more than 200 boaters on a waiting list for rack space.

Calusa also offers private and commercial wet slips; gas and diesel fuel; boat ramp, live bait; and Ship's Store where guests can purchase ice, snacks, clothing, maps and more. The wet slips can accommodate boats up to 60 feet and each features concrete floating docks, water, sewer, and cable television and cable access.



Scott Lawrence, operations manager.

Thoughts on the Neptune Series

Kris Dane, managing director & Scott Lawrence, operations manager

"Hoist has provided excellent service and has really stepped up to the plate in every way." - Kris

"The other trucks we have don't come close to the Neptune and Hoist. The Neptune outlifts the other trucks and Hoist has provided far superior service than what we've received from the other manufacturer. This truck has become our main truck and has been very reliable." - Scott

"I love the low-profile of the truck and the counterweight. It's looks sleek and the paint all-around is solid. The tilt-steering, air-ride seat, electronic controls and overall ergonomics is outstanding. The Neptune gives our guys a much smoother and quieter ride than our other trucks." - Scott

Hideaway Marina

Pompano Beach, Florida

**M250 Neptune Series
Delivered August 2006**

dry stack storage facility in South Florida for many years, serving as Roof & Rack's showcase project. Owner Pierre Gaudreau is responsible for the success of Sunseeker Yachts, introducing the line to the United States in 1988 and turning it into a household name. Looking to expand and go in a new direction after 14 years as the distributor and dealer, Gaudreau sold Sunseeker Yachts to Sunseeker England.

Pierre and his wife Danielle have grown their business tremendously over the past few years, including renovating Hideaway Marina after Hurricane Wilma. The Gaudreaus have expanded their boat lines to their dealership and have continued to provide excellent service support, maintaining a CSI score of 99.9%.

In 2005, a second facility was added in Fort Lauderdale to accommodate Hideaway Marina's growth. The 20,000-square-foot facility has boat storage, full paint services, and is the home to its boat transport division. Hideaway Yacht Collection was recently launched to be the importer and distributor of MAS by Prima, an Italian, custom high-tech powerboat, in the Americas.

Marina overview

Hideaway Marina is an authorized dealer for Sunsatation Powerboats, Outerlimits Powerboats, MAS by Prima and Deep Impact Powerboats. The marina's brokerage division offers top brands of powerboats and yachts such as Cigarette, Wellcraft, Sea Ray, Nor-Tech, Donzi, Azimut, Fountain, MTI, Fairline, Sunseeker and Riva. Hideaway Marina also has a 190-capacity high and dry storage facility, accommodating boats up to 50 feet.

Built in the mid 1980s by Roof & Rack, Hideaway Marina was the largest

Thoughts on the Neptune Series

Pierre Gaudreau, owner

"I like the visibility on the Neptune, especially through the mast. I also like the fact that the chains do not go into the water and that it has a tight turning radius. My operators really like the new fork covers that have been installed."

MDL Marinas/Drystack

United Kingdom

M220 Neptune Series (2)

Scheduled for delivery Spring 2007

Marina overview

Europe's largest marina group, MDL Marinas, is the owner and operator of 18 major marinas and boatyards, and more than 6,000 berths across Europe including: Queen Anne's Battery, Dartside Quay, Brixham Marina, Torquay Marina, Cobb's Quay Marina, Hythe Marina Village, Ocean Village Marina, Shamrock Quay, Saxon Wharf, Hamble Point Marina, Port Hamble Marina, Mercury Yacht Harbour, Northney Marina, Bray Marina, Windsor Marina, Penton Hook Marina, Woolverstone Marina and Chatham Maritime.

Established in the 1970s, MDL has played a significant role in the development of the modern-day marina with features such as easy-access pontoon berths, retail stores, restaurants, and commercial and residential properties. MDL's first location was on the River Thames in the UK.

Current projects

Penlee Quarry, located just south of Newlyn in Cornwall, will have 24-hour tidal access, which in conjunction with proposed schemes at Newlyn and Penzance, will greatly increase the sailing area to the West of Falmouth. Also, the Lizard will act as a convenient visiting point to those looking to sail onto the Scilly Isles, Ireland and France. Penlee will offer 195 berths, drystack facility, hotel, residential properties and retail. The scheme is at an early stage with a flexible approach being adopted so as to complement neighboring projects at Newlyn, Penzance and Scillies. MDL intends to create a high quality marina with good architecture and planning with a consideration being given to environmental opportunities such as harnessing energies from the sea.



Aerial view of Penlee Quarry.

The most significant and largest-scaled project to date for MDL is the redevelopment of Ocean Village in Southampton UK. MDL purchased Ocean Village from Associated British Ports (ABP) in 2000 with a goal of fully developing the area.

Ocean Village was the town's first dock in July 1843, then known as Princess Alexandra Docks. As time went on, it was expanded to handle cargo and international passenger ships. The cross-channel car ferry trade thrived in the basin between 1967 and 1984.

MDL plans to invest in the undeveloped land and provide a mix of urban uses centered around the marina basin. The existing buildings have long leases with between 100 and almost 1,000 years remaining, with the exception of Harbour Lights Cinema. MDL is planning to enhance the natural amphitheater of the basin to increase boat-related activity by redefining the basin, such as relocating car parking to allow for a broader mix of uses to bring activity back to the waterfront.

With hopes to make the area an destination for tourists and businesses, a 225-bed hotel has been proposed, which would be Southampton's first true waterfront hotel. Two distinct piazzas have also been proposed that would host various maritime events, concerts and festivities.



The proposed Millennium Hotel at Ocean Village.



MDL owns more than 18 marinas and boatyards and 6,000 berths in the UK. Currently, MDL Drystack has three locations that offer drystack storage -- Cobb's Quay Marina, Hamble Point Marina and Saxon Wharf.

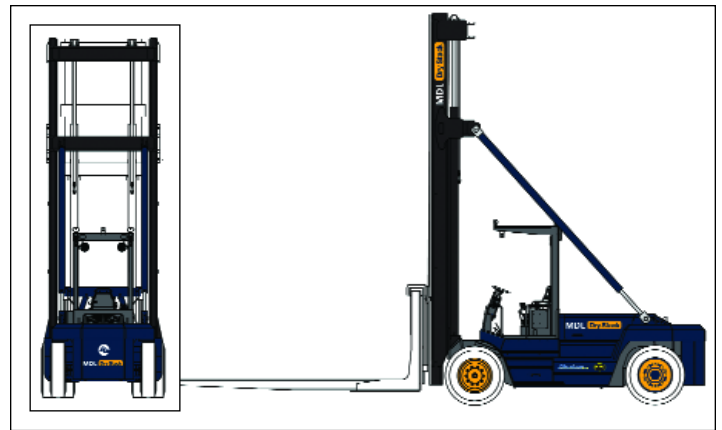

MDL Drystack locations

The two Neptune M220s will operate at Cobb's Quay Marina in Poole, Dorset UK and Hamble Point Marina in Hamble, Southampton UK. A third Neptune is currently being specified for Saxon Wharf in Northam, Southampton Hampshire. All three locations are scheduled to open this Spring. Saxon Wharf will be able to accommodate boats up to 42 feet, making MDL the largest capacity drystack provider in the UK.

Each of the marinas feature WiFi, showers, car parking, CCTV and a variety of other on-site services. MDL Drystack also offers a Club Outlook membership that gives members a 15-night visitor berthing pass as any of its marinas and other benefits including a 10% discount on fuel.

Thoughts on the Neptune Series

Phil Armstrong, project manager, MDL Drystack

"I was impressed by the professionalism of the Hoist employees; the design engineers were great in answering all our questions. Our MDL liftruck operators came over to the States to see the Neptune first-hand and returned suitably impressed."

"The standard components that are offered as options by other manufacturers were key. Competitive quotations were received from the outset; best prices were received early on which was important in the decision-making."

The Marina Club at BlackWater Sound

Key Largo, Florida

M240 Neptune Series
Scheduled for delivery Spring 2007

Marina overview

Located in the upper Florida Keys, The Marina Club at BlackWater Sound is an ideal spot for boaters -- two minutes from the Gulf of Mexico, 10 minutes from the Atlantic Ocean, 45 minutes from Miami and minutes from John Pennekamp State Park and Everglades National Park.

The Marina Club offers boaters a variety of fee-simple rackominium ownership packages to meet their needs and lifestyle. Interior and exterior dry storage spaces are available accommodating boats up to 40 feet. The Marina Club provides boats many services and amenities including: owner's lounge with free WiFi computer stations, plasma televisions, showers, dressing and restroom facilities, restaurants, catering, discounted fuel, an array of boat services, diving, bait and fish cleaning stations and five-star concierge services.



The Marina Club at BlackWater Sound will be a state-of-the-art marina with an array of features and amenities, including rackominium/boat condominium ownership.

Though The Marina Club at BlackWater Sound opens its doors this Spring, it has already sold out Phase I of its storage spaces and Phase II is quickly following suit.

Thoughts on the Neptune Series

Bruce Pagano, owner

"Technology was one of the key reasons why we chose the Neptune. I love the fact that the [RemoteTech] system has an email function telling me what the operator and machine are doing, as well as providing service reports."

"The operator has such better visibility than the other forklifts on the market. The low profile and see-through mast are great not only for operating purposes, but also safety."

"The [100% buy-back] warranty offered by Hoist demonstrated the faith they have in the machine, as well as their past performance in other industries with their other lines of forklifts."

MarineMax

Clearwater, Florida

Brant Beach, New Jersey

M250 Neptune Series (2)
Delivered August 2006 & October 2006

Marina overview

With more than 85 locations across the United States, MarineMax is a leading boat retailer and broker of brands such as Sea Ray, Boston Whaler, Meridian, Apremare, Bertram, Custome Line, Ferretti, Hatteras, Mochi Craft, Pershing and Riva.

MarineMax also offers a wide range of services including certified, factory-trained technicians, annual maintenance services, haul outs, bottom painting, engine re-powering, fiberglass and gel coat repair and full restoration. They also have Sea Ray and Mercury/MerCruiser replacement parts in stock, as well as a full boating gear center.

MarineMax also offers many financing options on new or pre-owned boats, as well as various insurance options. A dedicated online business department assists customers with services such as trade evaluations and finance options over the Internet.



**MarineMax in
Clearwater,
Florida**



Oakdale Yacht Service

Oakdale, New York

M220 Neptune Series
Delivered September 2006

Marina overview

Oakdale Yacht Service is a full-service marina located on the Connetquot River in Oakdale, Long Island, New York. Oakdale Yacht has dockage available for boats up to 55 feet, and high and dry storage for boats up to 35 feet.

Oakdale Yacht also offers a full-service fuel dock, restrooms with shower facilities, snack bar, bait shop, heated pool and gym. The facility has also been a certified Mercruiser/Mercury dealer for more than 20 years, as well as providing sales, repair and parts services for other brands such as Volvo, Yamaha and Yanmar. Also, as part of its service department, Oakdale Yacht provides repowering services to enhance the performance of boats.

Idle Hour

When some people think about the history of Oakdale, New York, extravagant mansions come into mind, most notably Idle Hour. In 1876, William K. Vanderbilt, grandson of railroad magnate Commodore Cornelius Vanderbilt, purchased 900 acres from Montauk Highway to the Great South Bay, on the east bank of the Connetquot River, which the estate was named Idle Hour.



Idle Hour mansion
Courtesy of NY Public Library



This layout shows the enormity of the 900-acre Idle Hour estate and the surrounding area.

Courtesy of E.A. White organization



Oakdale Yacht Service was one of the first marinas to have a Neptune Series with an enclosed cab.

With plans to serve as his summer and holiday residence, a lavish, 110-room wooden mansion was constructed in 1882. On April 15, 1899, while Vanderbilt's son, Willie K. II, was honeymooning there, the prominent Idle Hour residence was destroyed by a fire. Willie and his new bride escaped, but jokes quickly circulated that his wife was so hot that she was the reason for the fire.

The mansion was promptly rebuilt of red brick and gray stone, with exquisite furnishings, for a colossal \$3 million. The building at the time was considered among the finest homes in America. The most notable social event at Idle Hour was the 1895 wedding reception of Vanderbilt's daughter, Consuela, to the duke of Marlborough.

After Vanderbilt's death in 1920, the mansion went through several phases and visitors, including a brief stay during Prohibition by gangster Dutch Schultz. Around that time, cow stalls, pig pens and corn cribs on the farm portion of Idle Hour were converted into a short-lived bohemian artists' colony that included figures such as George Elmer Browne and Roman Bonet-Sintas. Now, the estate is the home of Dowling College.

Thoughts on the Neptune Series

Tom Crowley, owner

"It's amazing how spacious the cab is on the Neptune. You can fully stand up and walk around, which is great. Also, visibility is still excellent from all angles even with the cab."

"The remote control is great! It makes our operator's job easier and quicker. To be able to control the forks and mast from outside the truck is a wonderful thing."

"I also like the fact that the exhaust is in the rear of the truck and not on the side by the operator. It reduces the noise tremendously for the operator and the machine overall is very quiet."



Neptune



Taking your products to greater heights.

6499 W. 65th Street | Bedford Park, Illinois 60638

Phone: **800.367.5600** (US & Canada) | **708.458.2200** (International)

Fax: **800.367.5605** | **708.458.1176**

www.hoistlift.com